

Wall-Hung Urinal

PRODUCT FEATURES

- Compact design with internal trap
- Privacy shields
- Low lip design suitable for children

INLET

- Back inlet

PRODUCT SPECIFICATIONS

- Dimension : 360 (L) x 480 (W) x 745 (H) mm
- Material : Vitreous China
- Operating Pressure : 100 kPa - 800 kPa

DISCHARGE VOLUME

- Discharge Volume : 1.5L/flush



RESOURCEFUL FEATURES:



Water Spreader Device



Anti-Bacterial Technology

TECHNICAL DRAWING

INSTALLATION DETAILS

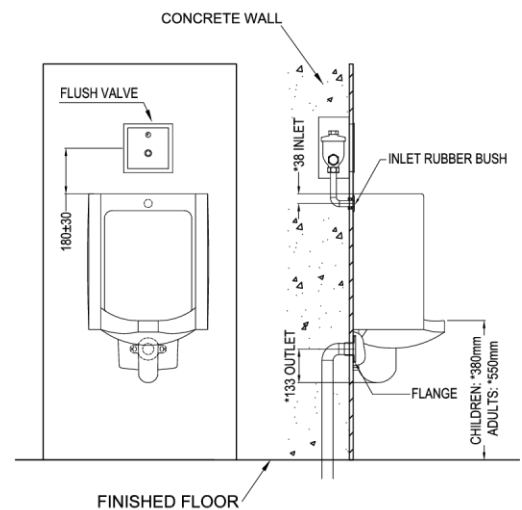
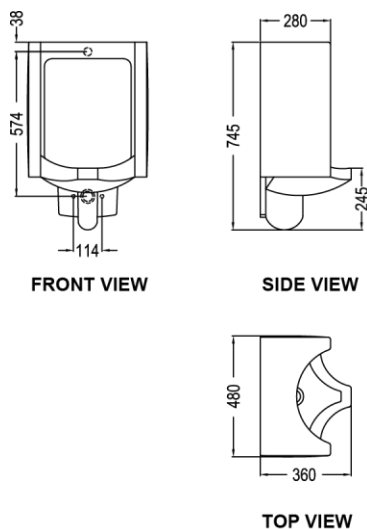

Copyright © Rigel Technology (S) Pte Ltd. All rights reserved. Terms of Use.